



CELECT

CELLULAR COMPOSITE SIDING



INSTALLATION HANDBOOK

TABLE OF CONTENTS

Product Offering

Siding Panels.....	4
Accessories.....	4–10

Installation

Storage & Handling	11
Wall Preparation	11
Key Rules of Installation	11
How to Measure	12–13
Fastening.....	15
Cutting and Routing	15
Touch Up	15
Glues and Sealants	15–16
Horizontal Lap & V-Groove Panel Installation.....	17–26
Installation Over Non-Nailable Sheathing	21
Board & Batten, Vertical V-Groove Panel Installation	27–36
Shake Panel Installation	37–45
Trim Assembly Models	46
Trimboard Joints.....	47
Gable Trim Use.....	48
Cleaning and Maintenance	49
Replacing Damaged Panel	50–52
Typical Window Profile Illustrations	53–55
Celect® Window & Door Trim	56
Celect® Canvas Cellular Siding	57–58
Royal® Spec Series™ Trim.....	59–63
Installing Shutters.....	64
Frequently asked Questions.....	65
Contractor Check Lists.....	66

Product Offering



Siding

Description	Product Code	Length	Unit Size	Color Palette	Profile Height
7" Horizontal Lap	CEL7	12' 4"	1 Sq./Carton	Full	3/4"
7" Shake	CELSHK7	4'	1/2 Sq./Carton	Full	3/4"
8" V-Groove	CELVG	12' 6"	1 Sq./Carton	Full	3/4"
8" Board & Batten	CELBB8	10'	1 Sq./Carton	Full	3/4"
11" Board & Batten	CELBB11	10'	1 Sq./Carton	Full	3/4"

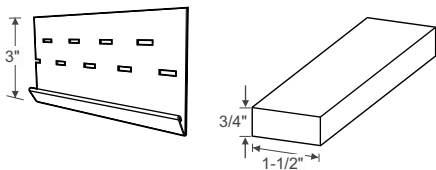

Starter Strip and Unpainted Furring Strip

Description	Product Code	Length	Unit Size	Color Palette
Starter Strip	CELSS01	12'	24/CTN	N/A
Unpainted Furring Strip	CELS4S1216UNP	16'	4/CTN	White

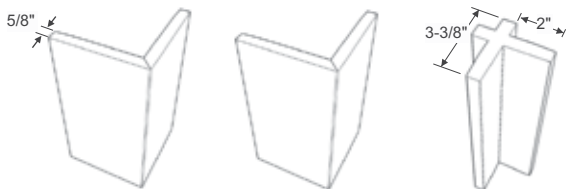

Corners

Description	Product Code	Exposure	Length	Unit Size	Color Palette
OCF 10'	COC1PSTD10KIT	5-1/2"	10'	2/CTN	Full
OCF 20'	COC1PSTD20KIT	5-1/2"	20'	2/CTN	Full
ICP 10'	CIS1PSTD10	2"	10'	2/CTN	Full

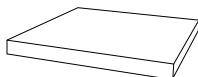

Trimboard

Nominal Size	Actual Size	Product Code	Length	Unit Size	Color Palette
5/8 x 4	5/8" x 3-1/2"	CELS4S58416	16'	2/CTN	Full
5/8 x 6	5/8" x 5-1/2"	CELS4S58616	16'	2/CTN	Full
5/8 x 8	5/8" x 7-1/4"	CELS4S58816	16'	2/CTN	Full
5/8 x 10	5/8" x 9-1/4"	CELS4S581016	16'	2/CTN	Full
1 x 2	3/4" x 1-1/2"	CELS4S1216	16'	2/CTN	Full
5/4 x 4	1" x 3-1/2"	CELS4S54416	16'	2/CTN	Full
5/4 x 6	1" x 5-1/2"	CELS4S54616	16'	2/CTN	Full
5/4 x 8	1" x 7-1/4"	CELS4S54816	16'	2/CTN	Full
5/4 x 10	1" x 9-1/4"	CELS4S541016	16'	2/CTN	Full

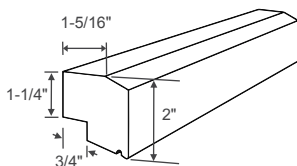
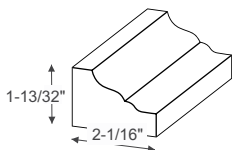

Crown and Sill Nose

Description	Product Code	Length	Unit Size	Color Palette
Rams Crown	CELRMSCRN16	16'	2/CTN	Limited
Sill Nose	CELSILL16	16'	2/CTN	Limited

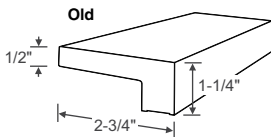
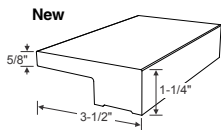

Window & Door Trim

Description	Product Code	Length	Unit Size	Color Palette
New! Window & Door Trim	CELWINT16	16'	2/CTN	Full
Window & Door Trim	CELWNTR	16'	2/CTN	Full

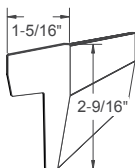

Gable Trim

Description	Product Code	Length	Unit Size	Color Palette
Gable Trim	CELGT16	16'	2/CTN	Full

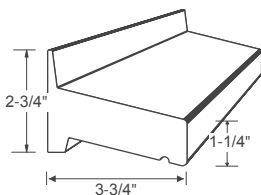

Stone Water Table

Description	Product Code	Length	Unit Size	Color Palette
Stone Water Table	CELSTWT	16'	2/CTN	Limited

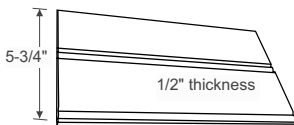

Beaded Plank

Description	Product Code	Length	Unit Size	Color Palette
Beaded Plank	CELDPLNK16	16'	2/CTN	Limited

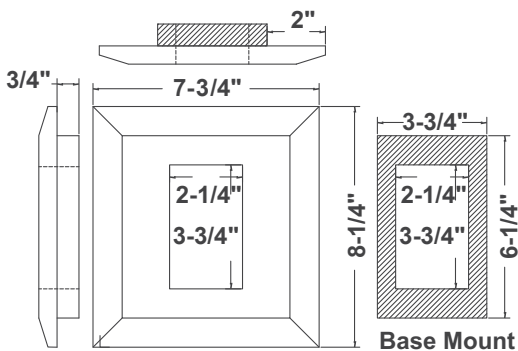
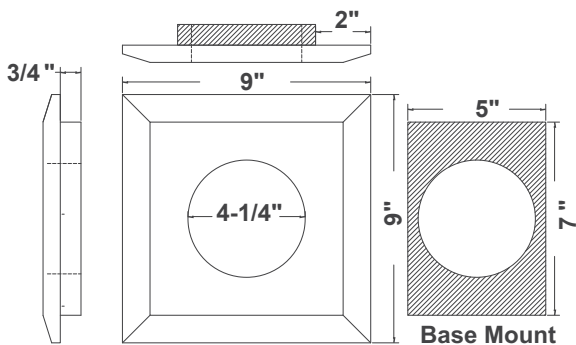

Blocks & Mounts

Description	Product Code	Unit Size	Color Palette
Vent/Light 9" x 9"	CELBVSH	1/BAG	Full
Electrical 8-1/4" x 7-3/4"	CELEMSH	1/BAG	Full

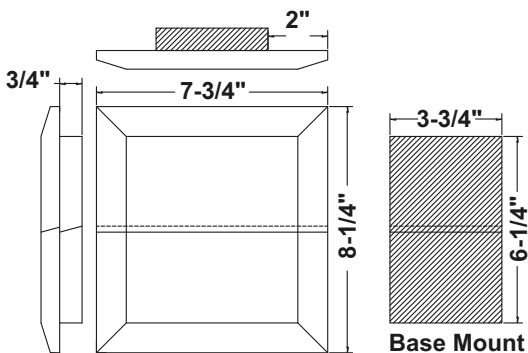
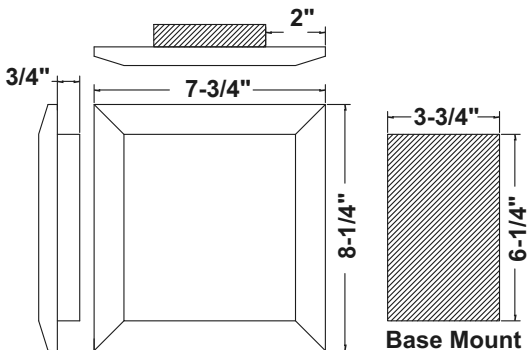

Blocks & Mounts

Description	Product Code	Unit Size	Color Palette
Universal 8-1/4" x 7-3/4"	CELSTMSH	1/BAG	Full
Split 8-1/4" x 7-3/4"	CELSPM SH	1/BAG	Full

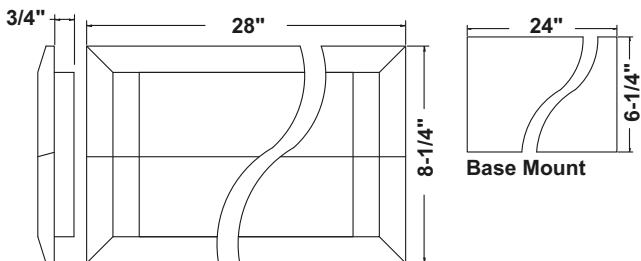
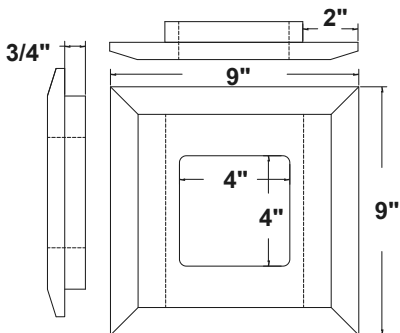

Blocks & Mounts

Description	Product Code	Unit Size	Color Availability
Recessed 9" x 9"	CELRCMSH	1/BAG	Frost, Canvas
Gang Block 28" x 8-1/4"	CELGGBSH	1/BAG	Frost, Canvas



Miscellaneous Accessories

Description	Product Code	Unit Size	Color Palette
Touch Up Bottle	CELTUBTTL	1/PACK	Full
Kynar Aquatec Celect Paint	CELQT	1 Quart	Full
Cortex Screws (Not sold by Royal)	CELCRTX250	375/CARTON	Full
Aluminum Trim Coil	CLCOIL50STD	24" x 50 ROLL	Full

Full Color Palette

Castle Stone CST	Imperial Red IMR	Timberland TBR
Chestnut CHT	Latte LAT	Willow WLW
Coastline COA	Oceana OCE	Wrought Iron WRI
Deep Pewter DPT	Pine Brook BK	Canvas NPT*
Frost FST	River Rock RRK	
Grove GRV	Shale SHL	

Limited Color Palette

Castle Stone CST	Shale SHL	Canvas NPT*
Frost FST	Willow WLW	
Latte LAT	Wrought Iron WRI	

Storage and Handling

If bundles are to be stored outside, do not lay them directly on the ground. Lay them on wood supports (e.g. 2 x 4). Do not store under dark tarps or plastic wraps and without air circulation.

Do not store bundles upright.

Do not store bundles more than 5 high.

Keep away from heat sources.

Keep cartons dry until opened.

Important: Handling of Celect Corner Posts

- Do not stack on top of corners.
- Store corners on level surface.
- Store out of direct sunlight.
- Keep corners in pack until installed.

Wall Preparation

Celect siding is a rain screen but not intended to be a water resistive barrier. Therefore, Celect siding must be installed over a continuous water-resistive barrier with properly integrated flashing.

Celect must be applied over rigid sheathing that provides a smooth flat surface. Never install Celect siding directly to open framing/studs. Celect must be installed over either solid nailable sheathing, rigid sheathing with minimum 1 x 6 furring strips or rigid sheathing and elongating the nailing slots (page 22).

Re-siding

It may not be necessary to remove existing siding providing all loose boards are re-secured and any rotten boards are replaced. Install furring strips or wall leveling siding underlayment to create a flat surface for the siding. Follow all other details outlined above.

Key Rules

- Nail in the center of the nailing slot unless pinning is necessary.
- Fasteners must be placed in the center of the nailing slots at approximately 16" spacing leaving about 1/32" between the head of the fastener and the nailing hem of the panel. Celect panels expand and contract through temperature changes.
- Never face nail the panels.

How to Measure

Estimating the Required Materials

- All houses can be broken down into shapes of rectangles or triangles, or a combination of both.
- The area to be sided can be determined by measuring the height and width of the house, including windows.
- Total all of the measurements for the areas to be sided. Windows and doors are not usually deducted. Including them will provide an allowance factor for waste. If the windows and doors are extremely large (such as a garage or sliding glass doors), some deductions can be made.
- To estimate the amount of starter strip required, measure the linear feet around the entire base of the house.
- Add siding to all material estimates to allow for waste, depending on the pitch of the roof and other house-specific factors.
- Every 100 square feet (9.29 square meters) is called a “square” for ordering purposes.

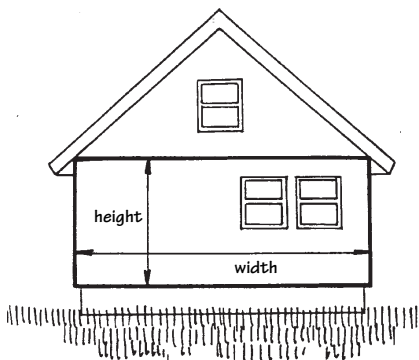

Horizontal Siding and Shingles

Height ___ feet (meters) x width ___ feet (meters) = ___ square feet (square meters)

Vertical Siding (Pieces of vertical siding)

Number of panels at ___ inches (mm) wide and 10 feet long
width ___ feet (meters), ___ inches (mm)

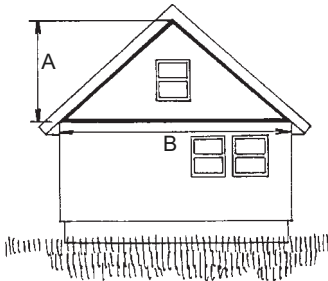

Horizontal Siding $\frac{1}{2} (A+B) \times C + \frac{1}{2}B \times D =$ ___total area of gable (square feet/meters)

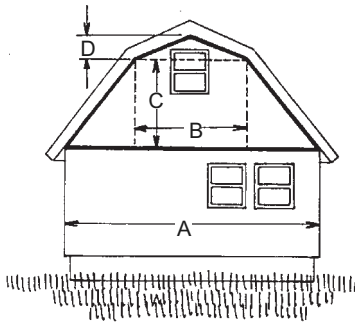

Horizontal Siding $\frac{1}{2} A \times B =$ ___total area of gable (square feet/meters)

$\frac{1}{2}$ height x width = ___area of dormer (square feet/meters)

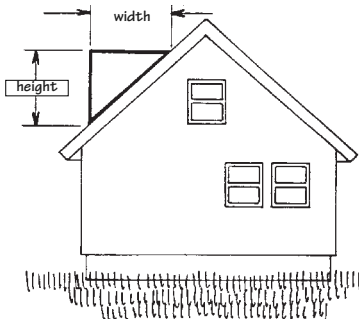

Fastening

Siding

- Corrosion-resistant nails (stainless steel nails or galvanized roofing nails) with a minimum head diameter of 3/8", 1/8" shank and length sufficient to penetrate a solid nailable surface (framing or furring) a minimum of 3/4" in depth. (minimum 2" length (50.8mm) in required in Canada).
- Note: High wind areas may necessitate ring shank nails.
- Corrosion resistant, #8 truss or pan head screws with a length sufficient to penetrate a solid nailable surface (framing or furring) a minimum of 3/4" in depth.
- Fasten siding to block or concrete as shown. Furring thickness and fastening methods are determined by local building codes.

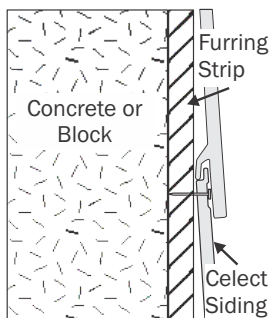

Trim

- Celect Cortex or Pro-Plug screws and plugs are recommended to secure finished Celect Trim pieces.
- If other trim fasteners are used, they must be fasteners intended for exterior use with PVC trim such as stainless steel or hot dipped galvanize.
- DO NOT USE staples, small brads, ring shank or wire nails.
- For "padding out" trim, fasteners should be long enough to penetrate the solid wood substrate a minimum of 1-1/2".
- Professional grade PVC adhesive for joining trim pieces. PVC adhesive along with Cyanoacrylate (super glue) and activator as a "clamp" can be used. (See Gluing page 13)

Cutting and Routing

Siding

Circular or miter saws with a trim or plywood blade. Jig saw, rotary tools (Dremel, router, etc.) can be useful for cutting around obstructions.

Trim

The use of compound miter saw with a trim blade is recommended.

Touch Up

- Use Celect Paint “dauber” bottle for larger areas and for coating exposed cut ends of Celect siding panels and trim.
- If repainting is necessary, use ONLY “heat reflective” paints formulated for use on PVC products. Follow the paint manufacturers application instructions.

Glues and Sealants

- Use Professional grade PVC adhesives for joining trim pieces.

Tip:

Two Part Gluing Method: PVC adhesive along with Cyanoacrylate (super glue) and activator as a “clamp” *can be* used. However, these glues are *not sufficient to use alone*. They must be used in conjunction with PVC cement. (2P10 is only an example of a Cyanoacrylate/Activator system. There are others.)



Using a Two Part Gluing Method

- First place a bead of PVC cement along one edge of one of the pieces to be glued.
- Next place a similar bead of Cyanoacrylate glue.
- Spray the activator along the other piece to be glued. **Do not spray the coated face of the piece.**
- Carefully join the two pieces together making sure that they are aligned properly. Hold the pieces in place for 5-10 seconds or until the Cyanoacrylate glue adheres. This will allow for installation of the piece and give sufficient time for the PVC cement to create a permanent bond.

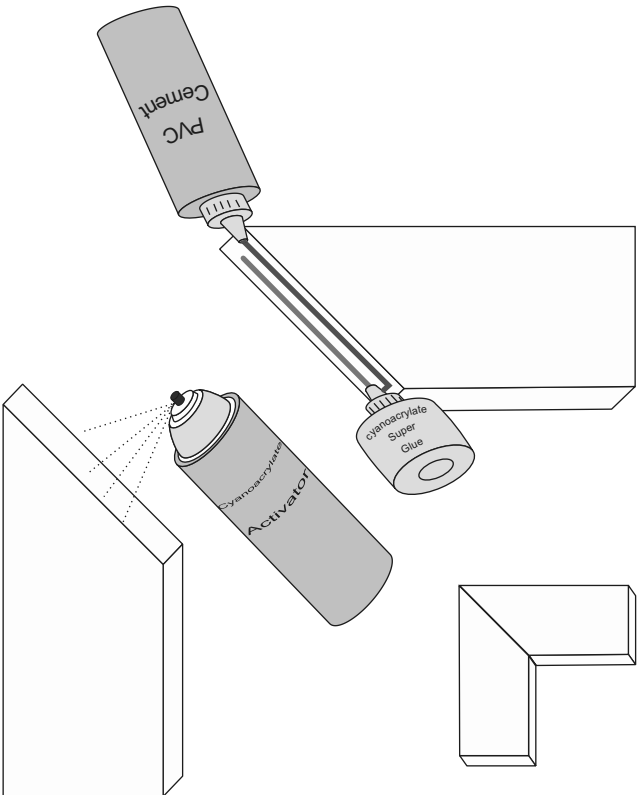

7" Lap & Horizontal V-Groove Installation

Installation Sequence

1. Weather Barrier & Flashing
2. Furring strips for trim
3. Inside Corner Posts
4. Starter Strip for Panels
5. Select Siding Panels
6. Window, Door, Etc. Trim

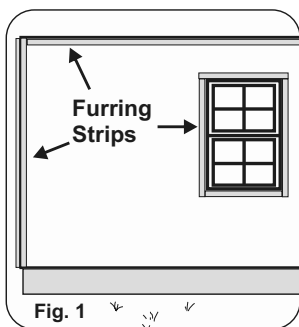

- After preparing the walls for the siding installation (see Wall Preparation pg. 1), install 1 x 2 furring around all windows, doors, outside corners, etc. This must be done anywhere the ends of the siding will be terminated (Fig.1-2).
- Make sure to install the proper flashing as required by specific local building codes (Fig.2)

NOTE: if the furring strips will be completely hidden by the trim, treated 1 x 2 furring can be used in place of PVC strips. Secure the furring every 8"–12".

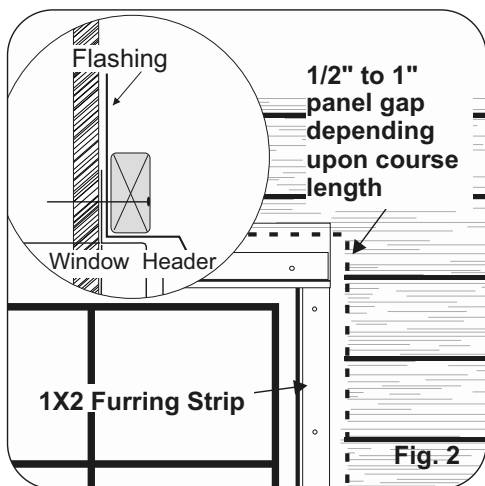

Starter Strip & Working Over Obstacles

Strike a chalk line 4" above the point you wish the bottom of the panel(s) to sit.

- Install starter strip aligning the top of the strip with the chalk line and fastening every 8"-12" (Fig. 3).

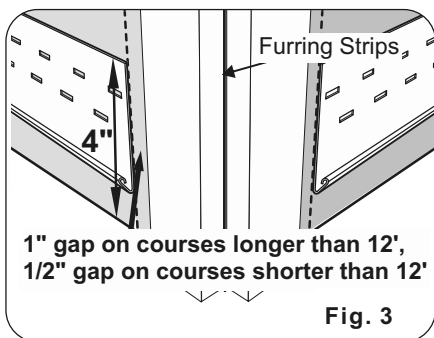

- In certain situations, it may be necessary to remove a bottom section from the panels to accommodate variations in the first course such as porch floors, etc. in these situations, where the bottom lock is removed, the cut edge of the panel(s) must be covered by trim. Select Trim can be used or custom trim can be fabricated with aluminum trim sheet. If trim sheet is used, keep in mind that the face of the channel or trim only needs to be wide enough to cover the cut edge of the panel by 1/2" (Fig. 4).

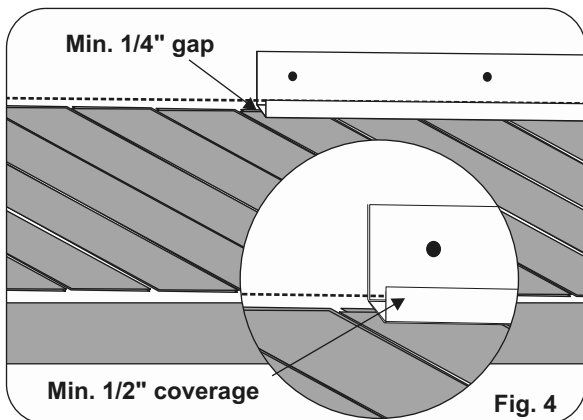

Inside Corner Posts

Install any inside corners. Fasten the inside corners using weather resistant screws placed inside the pocket of the corner no more than 16" apart (Fig. 5). Unlike the other finished trim, inside corners are applied before the siding.

NOTE: Make sure not to draw the pocket in when fastening to the wall.

The pocket width must remain $\frac{3}{4}$ ". Use a scrap piece of siding as a spacer in the pocket. The inside of the corner post should not lay against the siding.

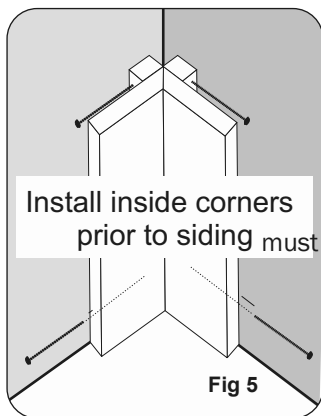

Expansion Gap

- Install the Select siding panels keeping the ends of the panels 1" away from the furring strips if the course is over 12' long, 1/2" away if the course is less than 12' long.

NOTE: If using 1/2", be sure to increase to 1" gap where courses become longer than 12' such as under and over windows.

- Fasten the panels by placing a fastener in the center of the slot approximately every 16" leaving about 1/32" between the head of the fastener and the nailing hem of the panel. Select panels expand and contract through temperature changes. (Fig. 7).
- If the course is longer than 12' pin the center of the course (not each panel) by placing a fastener in each side of one slot keeping in mind that the "center" of each course will change as you work around windows, doors, etc. (Fig. 8).

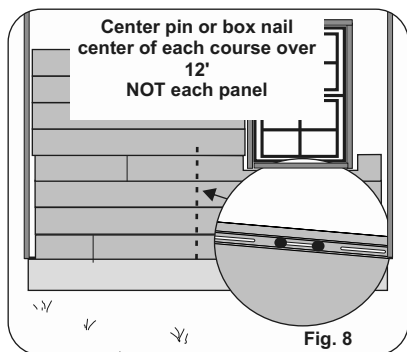
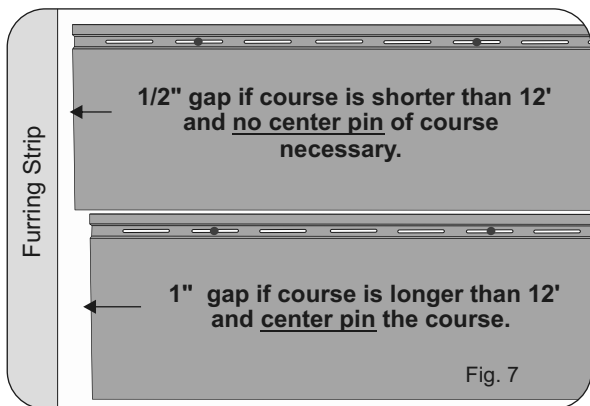

Maximum Wall Length

- Select siding panels can be installed continuously up to 60'. If the siding courses are longer than 60', break the course(s) with an expansion joint. This joint can be fabricated using furring strip and 1' x 6" (Fig. 9).

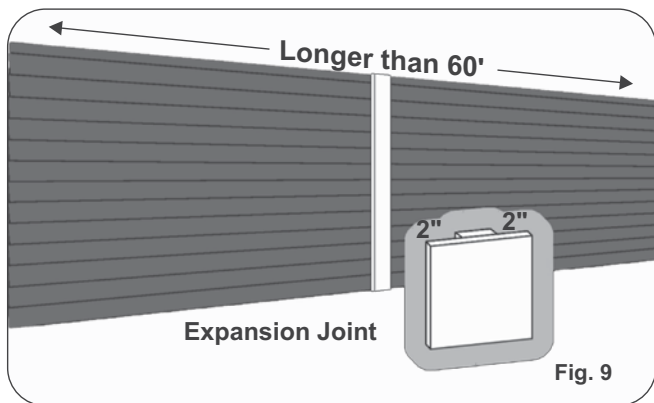

Installation Over Non-Nailable Sheathing

- In situations where it is not possible to place the nail in the center of the nailing slot (foam sheathing, etc.) it is permissible to remove the material in between two slots to allow for more room for expansion and contraction (Fig.10).
- Make certain that:
 1. There is a minimum of 1" between a nail and the end of the nailing slot.
 2. The edges of the extended slot are cut cleanly and even with the existing slots.

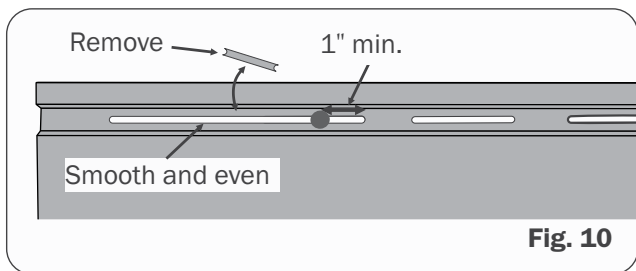

Roof Lines

- When installing over roof lines, use the same 30' rule. If the longest panel will be under 30', there is no need for a trimboard. The panels can be installed within 1/2" from the roof line and pinned there to hold the panel edges even; letting them expand and contract away from the pinned area.
- If the longest panels will be over 30' in length, there must be a furring installed, a 1" gap between the furring and the end of the panel(s) and a trimboard installed to hide the ends of the panel(s). (Fig. 11-12)

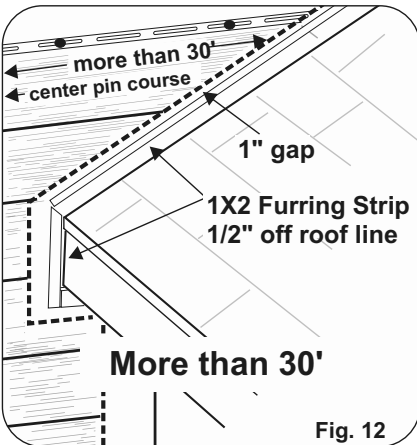
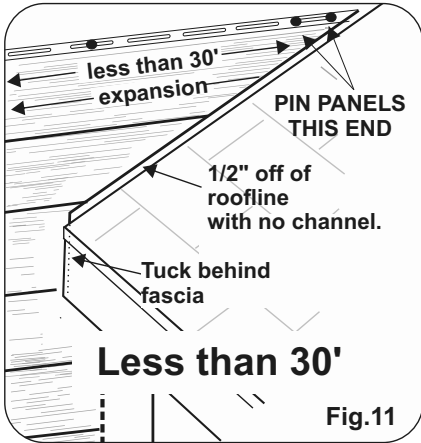

Gable Trim

The gable trim is a suitable alternative to a standard trimboard if a small profile is desired.

NOTE: Gable trim is not designed for use as window trim.

- Measure from the soffit 1-1/2" and strike a chalk line.
- Install the panels aligning the ends with the line leaving the 1-1/2" gap for panel expansion and contraction.
- The width of the gable cannot extend beyond 30'. For gables beyond 30', a furring strip and minimum 3-1/2" trimboard should be used.
- Install the gable trim using Cortex or Pro Plug screws and matching plugs. Place fasteners approximately every 12"–16" being careful not to place them in the expansion gap.

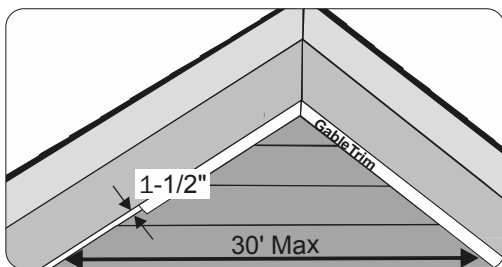

Cutting Miters on Gable Trim

The multiple angles designed into the finish trim and the gable trim allow for the adjustment of the pocket width desired depending upon the application. However, if the installation includes mitering two adjacent pieces of trim together such as the peak of a gable, it is important that the trim be placed correctly when cutting as shown in figure 13. A scrap piece of 3/4" thick material can be used as a guide to making placement easier.

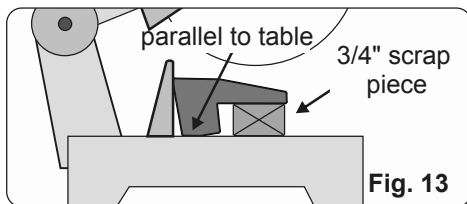

Fixture Mounts

- Celect fixture mounts are available for obstructions such as lighting, dryer vents, water faucets, etc. Begin by installing the base "ring." Install the siding panels allowing for the appropriate expansion gap depending upon the length of the siding course. Center and secure the face plate with two Celect Cortex trim screws and plugs (Fig. 14).
- Fixture mounts can also be field constructed using Cellular PVC, wood, etc. The pocket depth must be be 2" for courses over 12' and 3/4" for courses under 12' to allow for the appropriate expansion gap.
- For courses under 12' preformed vinyl siding fixture mounts can be used. In this case, the expansion gap should be 3/8".

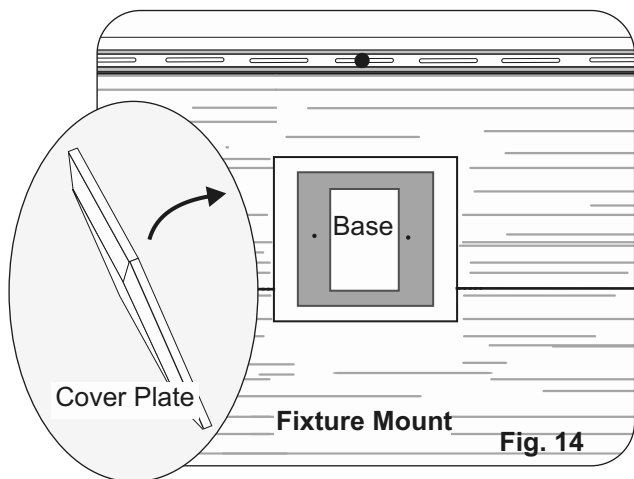

Top Course Installation

- Depending upon the trim you choose to use to finish the top of the wall, measure and cut the top course panel to fit. A freeze board or gable trim can be applied to cover the fasteners and give a finished appearance.
- Install the panel securing it by placing nails along the the cut edge of the panel approximately every 16". **DO NOT FACE NAIL THE PANEL.** The head of the nails will hold the panel back to the wall and the shaft of the nail will keep the panel from raising and becoming unlocked from the panel below it (Fig. 15).

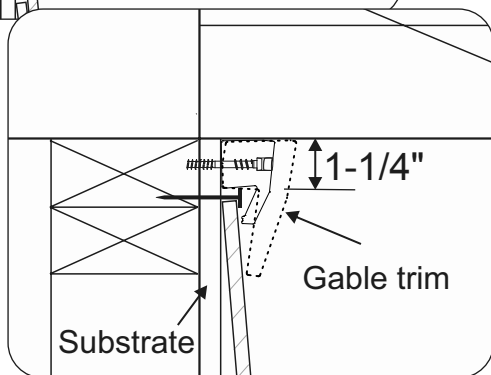
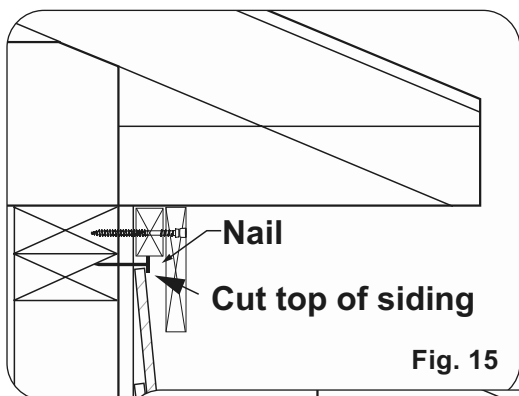

Trim Installation

- Install trim over furring strips (Fig. 16-17). It is easiest to assemble window and door trims before applying them to the wall. When using Celect trim, be sure to build the trim slightly larger (1/8" each side) than the window or door to give the finished frame room to expand and contract through temperature changes.
- Cortex® or Pro Plug® screws and matching plugs should be used when installing Celect trim. Space the fasteners no more than 16" apart and no closer than 2" from the end of the trim. Make sure not to fasten through the siding or into the expansion pocket.

NOTE: See trim assembly section for more.

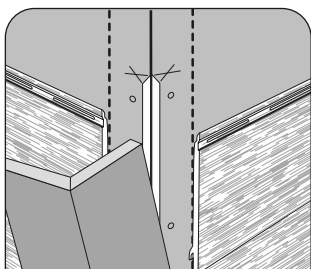

Fig. 16



Cortex® Hidden Fastening System

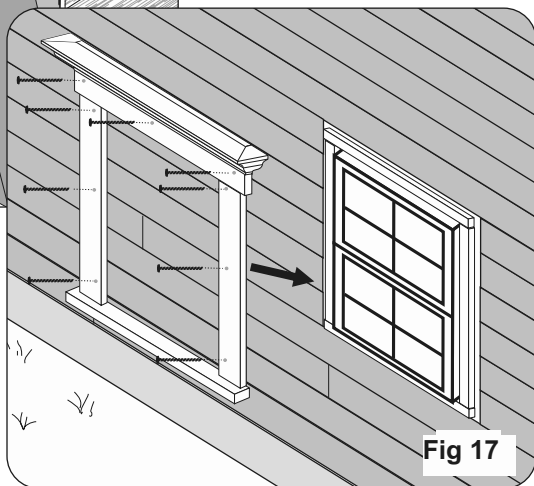
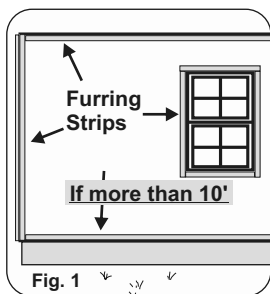

Fig 17

Board & Batten and Vertical V-Groove Installation

Board & Batten

1. Weather Barrier & Flashing
2. Furring strips for trim
3. Inside Corner Posts
4. Select Board & Batten Siding Panels
5. Window, Door, Etc. Trim



- After preparing the walls for the siding installation (see Wall preparation pg. 8), install 1x2 furring around all windows, doors, outside corners, etc. This must be done anywhere the ends of the siding terminate with the exception of along the bottom of the course up to 10'. If the panels are longer than 10' a furring strip and trim will be necessary along the bottom as well. (Fig. 1-2)
- Make sure to install the proper flashing as required by specific local building codes (Fig. 2)

NOTE: If no solid nailable substrate exists, either furring strips installed horizontally at 12" spacing for 8" exposure Board & Batten panels, 8" spacing for 11" exposure Board & Batten panels or solid nailable sheathing **MUST** be applied prior to the installation of the vertical panels.

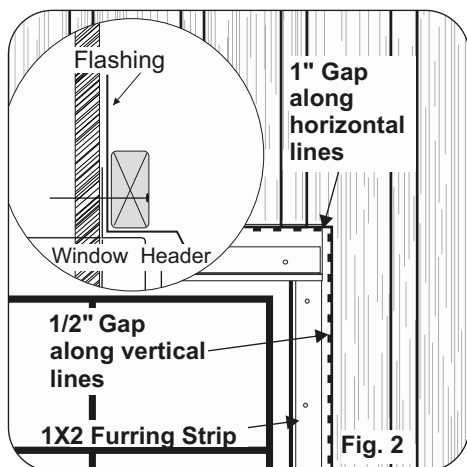

Inside Corner Posts

Inside corner posts are the only finish “trim” piece to be installed prior to the siding panels.

- Install any inside corners. Fasten the inside corners using weather resistant screws placed inside the pocket of the corner no more than 16" apart. Unlike the other finished trim, inside corners are applied before the siding.

NOTE: Make sure not to draw the pocket in when fastening to the wall.

The pocket width must remain 3/4". Use a scrap piece of siding as a spacer in the pocket. The inside of the corner post should not lay against the siding.

- As a general rule, you will install panels from the inside corner outward on both sides.
- **If installing between two inside corners,** 1) install one inside corner, 2) install the panels then, 3) install the other inside corner. This way you can secure the last panel going into the second inside corner. Note that you will only be able to secure the second inside corner on one side. Be careful to keep it even and square to the corner.

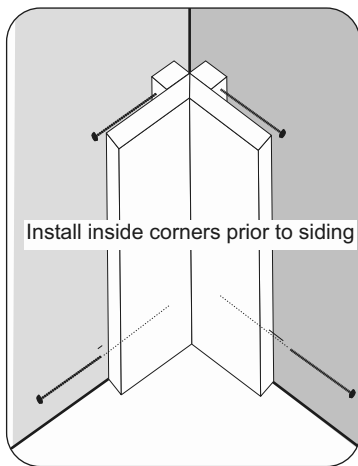

Creating a Balanced Appearance

It's important to create a more "balanced" appearance across the wall; meaning, the batten strips appear to be the same distance from both corners. The following describes how to achieve this.

- Using a chalk line, strike a plumb line $1/2"$ from the furring strips on both the starting side and the ending side.
- Divide the length of the wall in inches by 8 for 8" panels or 11 for 11" panels (Fig. 3)
- Then divide any fraction of a panel into 2. This will give you the width of exposure for both the starting panel and the ending panel (Fig. 4).

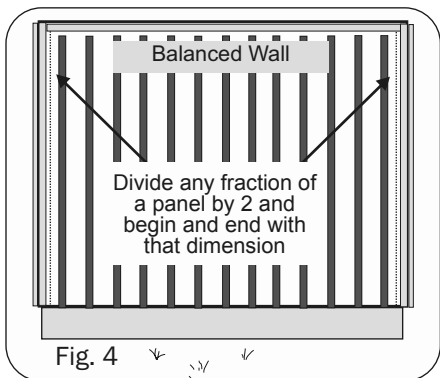
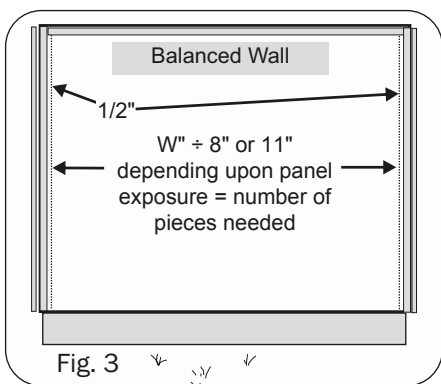

First Panel

Once the exposure for the first panel has been calculated (Fig. 3-4), measure from the edge above the nailing slots across the panel the calculated measurement plus $3/8"$ to compensate for the lock on the panel.

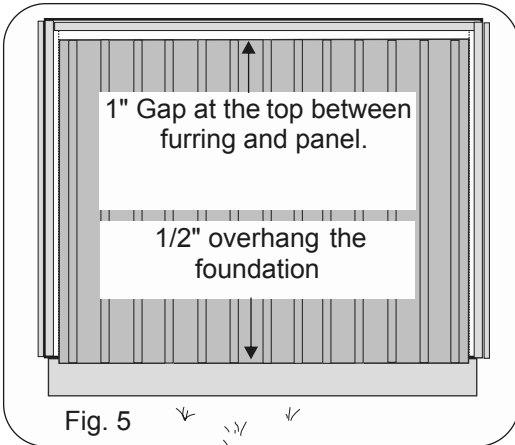
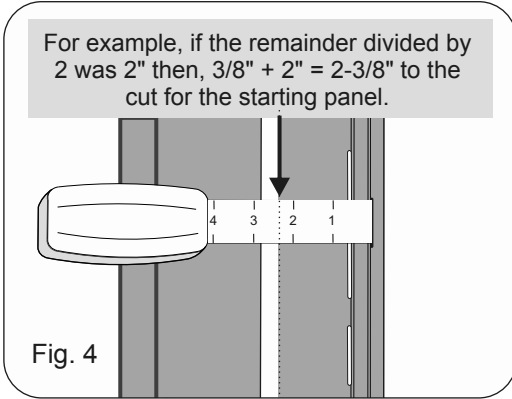

Panel Installation

- The length of the panel should be 1" from the top furring and a minimum of 1/2" over the foundation at the bottom (Fig. 5)
- Install the first panel by placing the cut edge along the chalk line.
- Hold the panel in place by placing the first fastener at the top of a nailing slot no more than 12" from the bottom edge of the panel. Do not drive tight. Leave approximately 1/32" between the head and the panel.
- Make sure the panel is plumb and continue fastening it placing the fasteners in the center of the slots at intervals of 8" for 11" panels and 12" for 8" panels (Fig. 6)

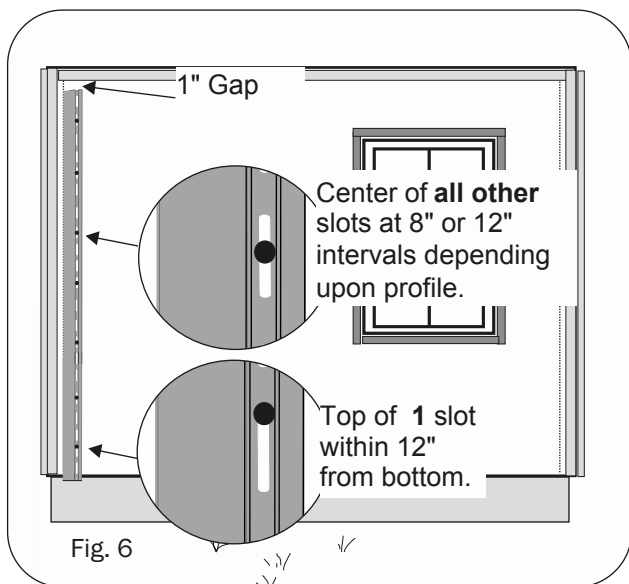

Panel Installation Cont'd

- Continue installing panels across the wall making certain that 1) the lock is fully engaged and 2) the panel is "pinned" into place by 1 fastener within 12" of the bottom of the panel.
- For the best look, make sure that all the panels are even across the bottom of the wall.
- When cutting and installing around windows, doors, etc., allow for 1/2" gap along any vertical cuts always and 1/2" along horizontal cuts up to 8' and 1" beyond 8' (Fig. 7)

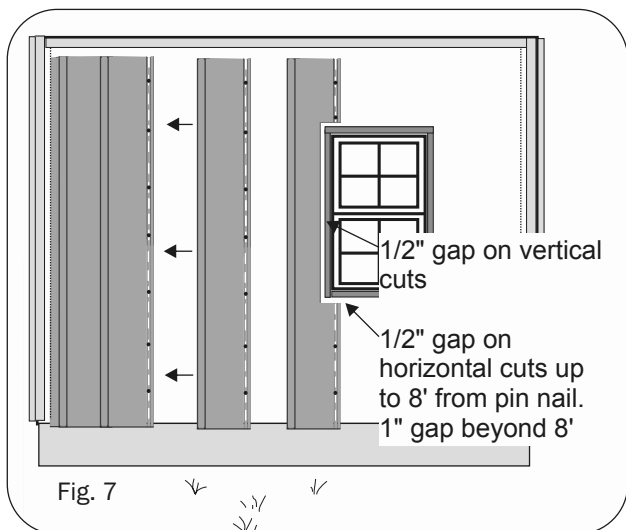

More Than One Course

If the wall is taller than one course (above 10'), the courses must be separated by a transition piece. The diagram below shows two examples. Note that, if the panels are being held closer than 1" to trim at the bottom of the course, there must be a 1" gap at the top to allow for expansion of the panel(s).

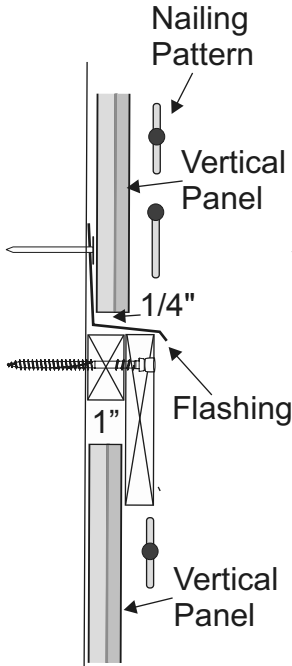

Fixture Mounts

- Celect fixture mounts are available for obstructions such as lighting, dryer vents, water faucets, etc. Begin by installing the base "ring." Install the siding panels allowing for the siding course. Center and secure the face plate with two Celect Cortex trim screws and plugs (Fig. 8).
- Fixture mounts can also be field constructed using Cellular PVC, wood, etc. The pocket depth must be 2" for courses over 12' and 3/4" for courses under 12' to allow for the appropriate expansion gap.
- Preformed vinyl siding fixture mounts can be used. In this case, the expansion gap should be 3/8".

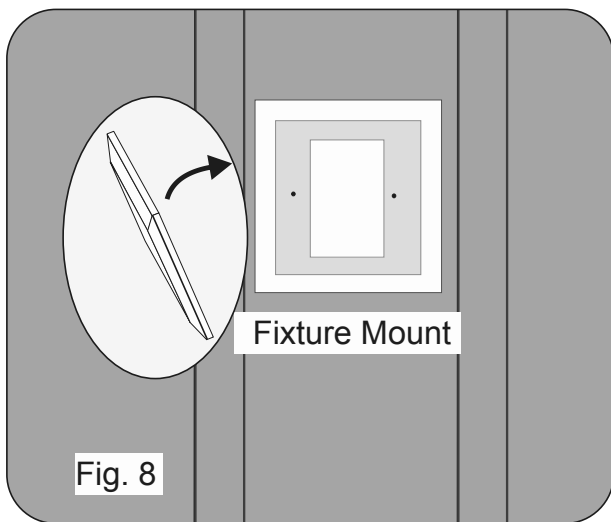

Final Panel Installation

- Measure for the last panel by measuring from above the nailing hem of the next to last panel to the chalk line and add 1-1/2".
- Measure from the batten strip side of the last panel and cut.
- Prior to installing the panel, pre-drill a hole within 12" of the bottom of the panel to hold it in place. The hole should be slightly larger than the shaft of the fastener.
- Install the panel and place a fastener through the pre-drilled hole.
- Continue to secure the panel by placing fasteners along the cut edge of the panel at 8" or 12" intervals. The fastener head will hold the panel back. Do not fasten tightly and **do NOT place the fasteners through the panel** (Fig. 9).

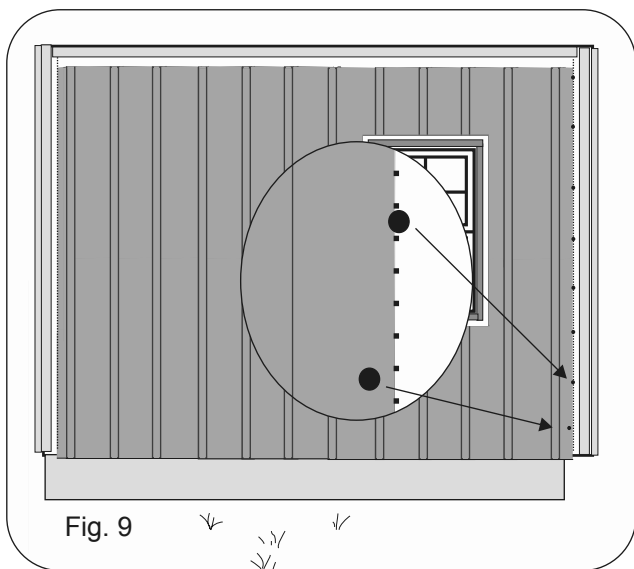

Trim Installation

- Install trim over furring strips (Fig. 10-11). It is easiest to assemble window and door trims before applying them to the wall. When using Celect trim, be sure to build the trim slightly larger (1/8" each side) than the window or door to give the finished frame room to expand and contract through temperature changes.
- Cortex® or Pro Plug® screws and matching plugs should be used when installing Celect trim. Space the fasteners no more than 16" apart and no closer than 2" from the end of the trim. Make sure not to fasten through the siding or into the expansion pocket (Fig. 11).

NOTE: See trim assembly section for more.

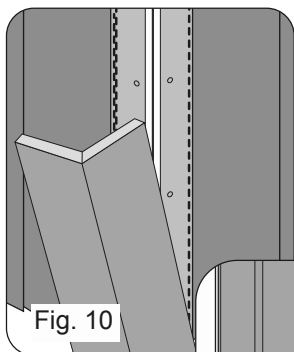

Fig. 10



Cortex® Hidden Fastening System

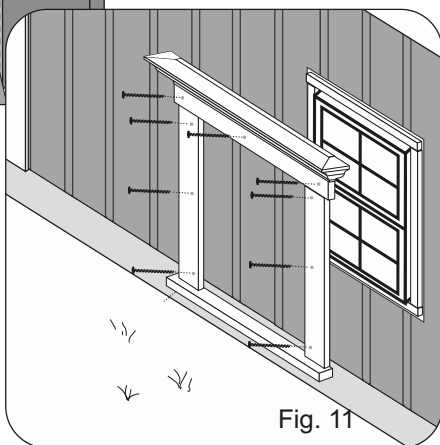
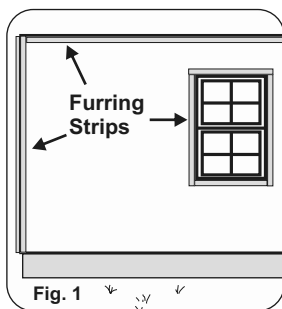

Fig. 11

Celect Shake Installation

Installation Sequence

1. Weather Barrier & Flashing
2. Furring strips for trim
3. Inside Corner Posts
4. Starter Strip for Panels
5. Celect Siding Panels
6. Window, Door, Etc. Trim



- After preparing the walls for the siding installation (see Wall Preparation pg. 1), install 1x2 furring around all windows, doors, outside corners, etc. This must be done anywhere the ends of the siding will be terminated (Fig. 1-2).
- Make sure to install the proper flashing as required by specific local building codes (Fig. 2).

NOTE: If the furring strips will be completely hidden by the trim, treated 1x2 furring can be used in place of PVC strips. Secure the furring every 8"–12".

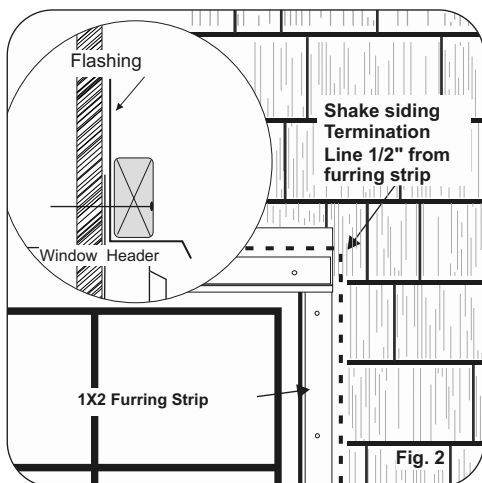

Starter Strip & Working Over Obstacles

- Strike a chalk line 4" above the point you wish the bottom of the panel(s) to sit.
- Install starter strip aligning the top of the strip with the chalk line and fastening every 8"-12" (Fig.3).

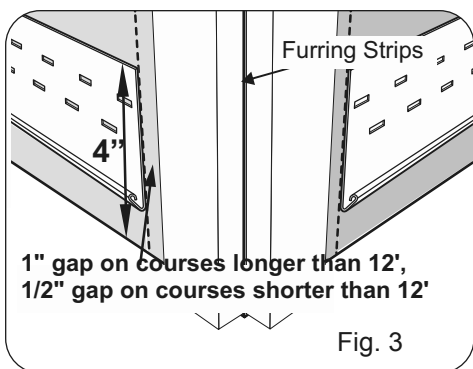

- In certain situations, it may be necessary to remove a bottom section from one of the panels to accommodate variations in the first course such as porch floors, etc. In these situations, where the bottom lock is removed, the cut edge of the panel(s) must be covered by trim. Select Trim can be used or Custom trim can be fabricated with aluminum trim sheet. If trim sheet is used, keep in mind that the face of the channel or trim only needs be wide enough to cover the cut edge of the panel by 1/2" (Fig. 4).

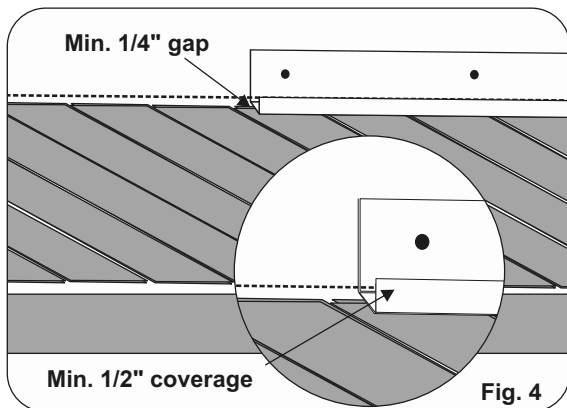

Inside Corner Posts

Inside corner posts are the only finish “trim” piece to be installed prior to the siding panels.

- Install any inside corners. Fasten the inside corners using weather resistant screws placed inside the pocket of the corner no more than 16" apart. Unlike the other finished trim, inside corners are applied before the siding.

NOTE: Make sure not to draw the pocket in when fastening to the wall. The pocket width must remain $3/4"$. Use a scrap piece of siding as a spacer in the pocket. The inside of the corner post should not lay against the siding.

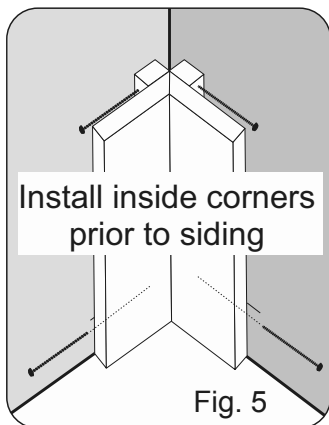

Installing Panels

- Panels install left to right.
- Install the first panel locking it down onto the starter strip and keeping the left end of the panel $3/8$ " away from the furring strip.
- Fasten the panels by placing fasteners into the nailing flange; one in the center of the panel and two on either side, evenly placed. Keep fasteners approximately 2" from both ends. (Fig. 6).

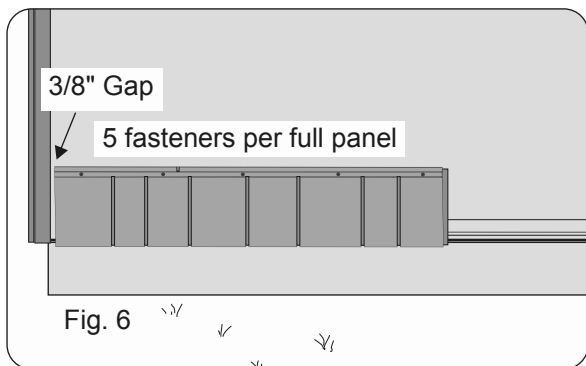

- Install the remainder of the course overlapping the seams and leaving the necessary space between the shakes. If the temperature is above 70°F leave $1/8$ ", if the temperature is below 70°F leave $1/4$ " (Fig. 8).

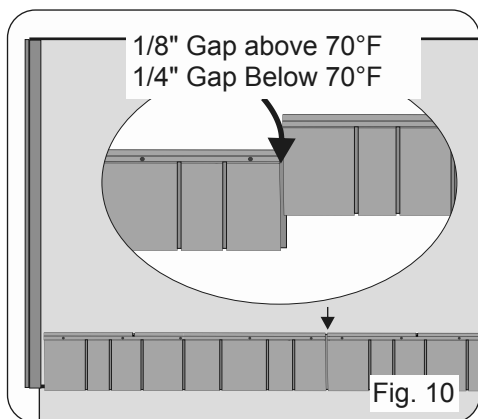

- Measure for the starting panel of the second and remaining courses by measuring from the closest indexing mark to the corner (Fig. 9).
- Measure and cut the panel so the right end of the panel will align with the indexing mark.
- Fasten and complete the courses.

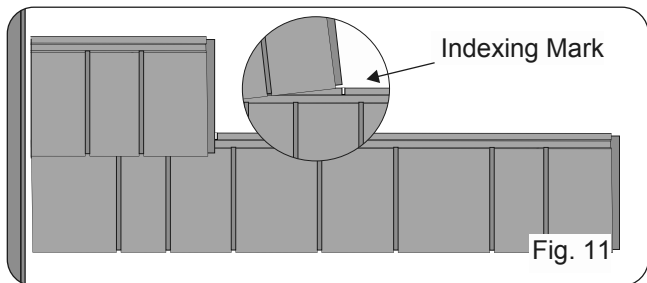

Gables

- The same 3/8" gap should be left in gable areas or anywhere the ends of the panels terminate (Fig. 7). Either Trimboard, Finish Trim or Gable Trim (Fig. 8,9) can be used.

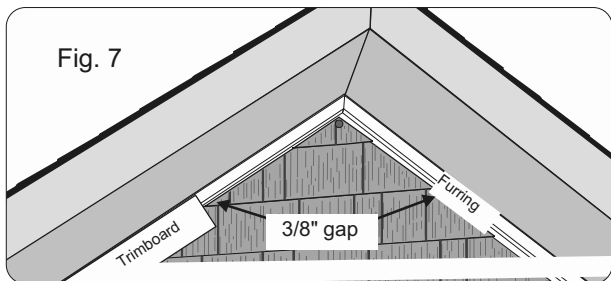

Using Gable Trim

The gable trim is a suitable alternative to a standard trimboard if a small profile is desired.

- Measure from the soffit 1-1/2" and strike a chalk line.
- Install the panels aligning the ends with the line leaving the 1-1/2" gap for panel expansion and contraction
- Install the gable trim using Cortex or Pro Plug screws and matching plugs. Place fasteners approximately every 12"–16" being careful not to place them in the expansion gap.

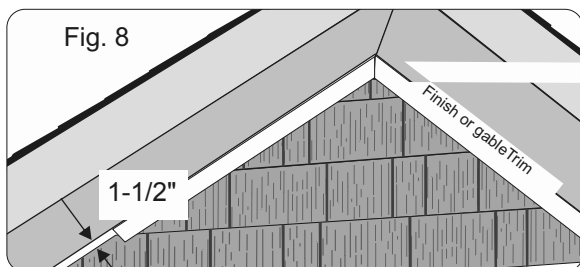

Cutting Miters on Gable Trim

The multiple angles designed into the finish trim and the gable trim allow for the adjustment of the pocket width desired depending upon the application. However, if the installation includes mitering two adjacent pieces of trim together such as at the peak of a gable, it is important that the trim be placed correctly when cutting as shown (Fig. 9). A scrap piece of 3/4" thick material can be used as a guide for making placement easier.

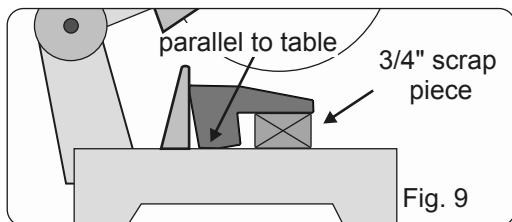

Installing Panels

- Select fixture mounts are available for obstructions such as lighting, dryer vents, water faucets, etc. Begin by installing the base "ring." Install the siding panels allowing for the appropriate expansion gap depending upon the length of the siding course. Center and secure the face plate with two Select Cortex trim screws and plugs (Fig. 10).
- Fixture mounts can also be field constructed using Cellular PVC, wood, etc. Allow for the appropriate 3/8" expansion gap.

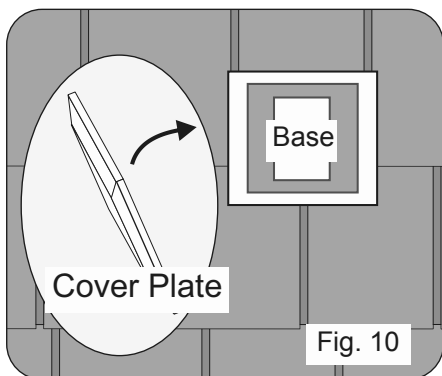

Roof Lines

- When working up over roof lines, hold the shake panels off the roof line a minimum of 1/2". No additional trim is needed (Fig. 11).

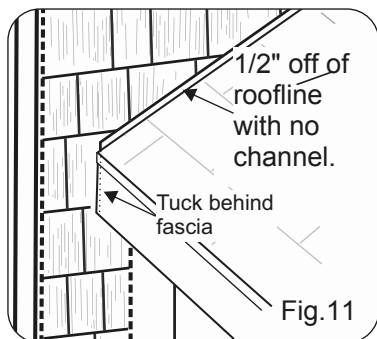

Top Course Installation

- Depending upon the trim you choose to use to finish the top of the wall, measure and cut the top course panel to fit. A freeze board or gable trim can be applied to cover the fasteners to give a finished appearance.
- Install the panel securing it by placing nails along the cut edge of the panel approximately every 16". The head of the nails will hold the panel back to the wall and the shaft of the nail will keep the panel from raising and becoming unlocked from the panel below it (Fig. 12). Pin each panel in place by placing one nail through the panel itself toward the middle of the panel (Fig. 13).

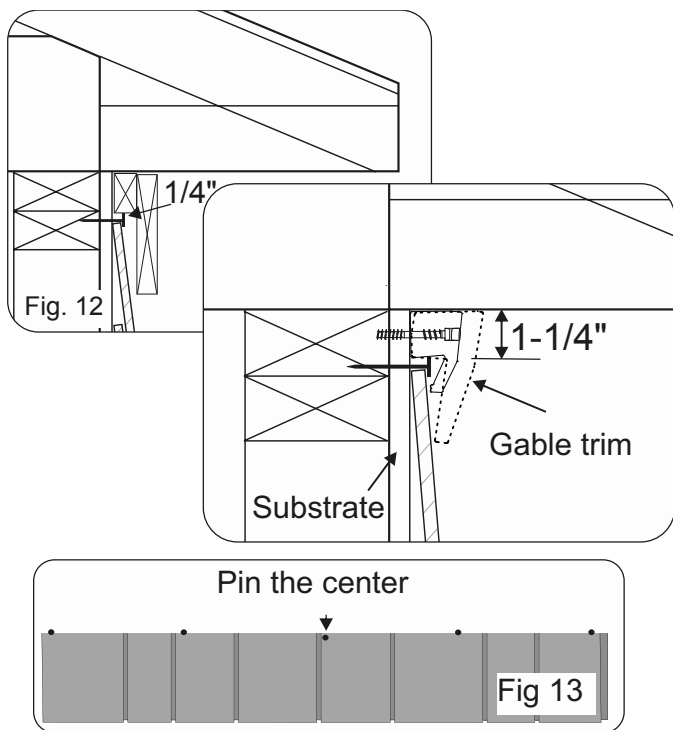

Trim Installation

- Install trim over furring strips (Fig. 13-14). It is easiest to assemble window and door trims before applying them to the wall. When using Celect trim, be sure to build the trim slightly larger (1/8" each side) than the window or door to give the finished frame room to expand and contract through temperature changes.
- Cortex® or Pro Plug® screws and matching plugs should be used when installing Celect trim. Space the fasteners no more than 16" apart and no closer than 2" from the end of the trim. Make sure not to fasten through the siding or into the expansion pocket (Fig. 14).

NOTE: See trim assembly section for more.

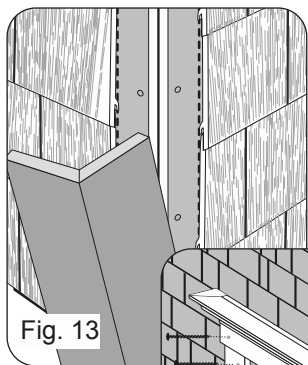

Fig. 13



Cortex® Hidden Fastening System



Fig 14

Trim Assembly Models

Fastening

Cortex® or Pro Plug® screws and matching plugs are recommended to secure Celect trim.

Skirt Board Width	Fasteners/width 16" O.C. Max
4"	1
6"-8"	2
10"-12"	3

Stone Water Table & Skirt Board

- Make sure that the wall is made weather resistant consistent with building codes. If no wrap is used, flash a minimum of 10" up from the bottom, hanging the flashing at least 1/4" over the bottom of the sill plate.
- Install the stone water table as shown below using weather resistant screws at 8-12" intervals.
- Install flashing at seams as shown.

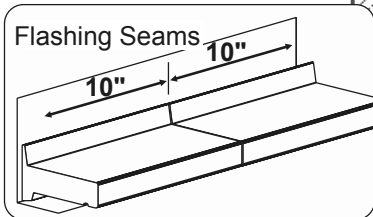
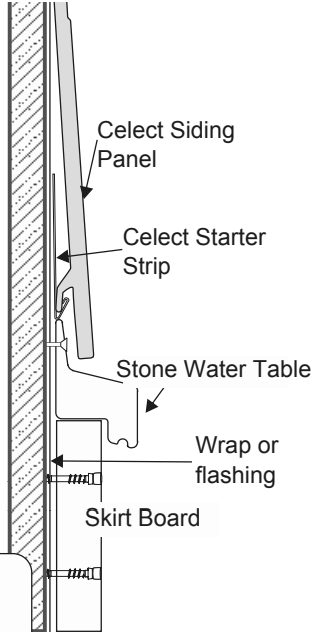

Trimboard/Fascia Joints

When joining boards in areas such as under eaves or on fascia, a shiplap joint is recommended with the exception of at corners; a mitered corner will give the best appearance.

Inside Corner Posts

When mitering a corner, the following rules apply:

- The trimboard with a mitered end should be no longer than 4'
- Always glue the ends of the boards with PVC cement.
- Place a fastener 2" from the seam on both sides.

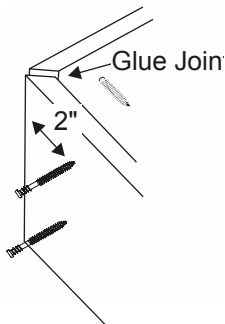

Managing Expansion/Contraction on Longer Runs

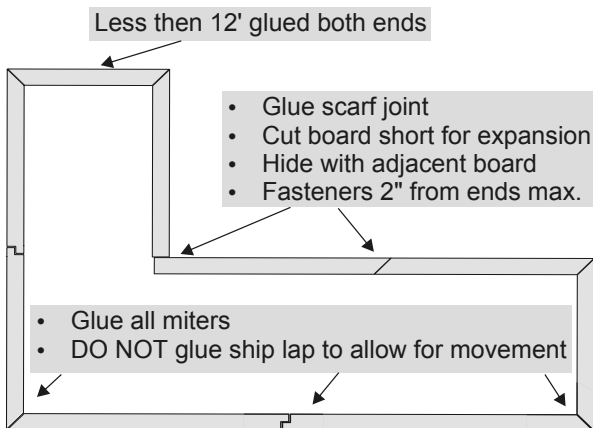

Place a fastener 2" from the seam on both sides.

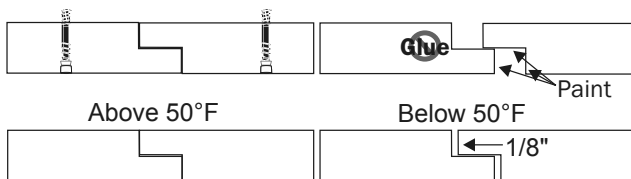

Gable Trim

The gable trim is a suitable alternative to a standard trimboard if a small profile is desired.

- Measure from the soffit 1-1/2" and strike a chalk line.
- Install the panels aligning the ends with the line leaving the 1-1/2" gap for panel expansion and contraction.
- The width of the gable cannot extend beyond 30'. For gables beyond 30', a furring strip and minimum 3-1/2" trimboard should be used.
- Install the gable trim using Cortex® or Pro Plug® screws and matching plugs. Place fasteners approximately every 12"–16" being careful not to place them in the expansion gap.

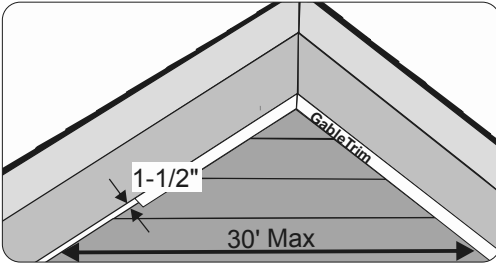

Cutting Miters on Gable Trim

The multiple angles designed into the finish trim and the gable trim allow for the adjustment of the pocket width desired depending upon the application. However, if the installation includes mitering two adjacent pieces of trim together such as at the peak of a gable, it is important that the trim be placed correctly when cutting as shown in figure 9. A scrap piece of 3/4" thick material can be used as a guide to making placement easier.

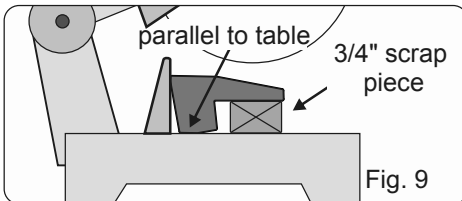

Cleaning and Maintenance

- Always test a small area of the wall in an inconspicuous location first, prior to attempting to use any cleaning solution or method to ensure no damage occurs.
- Use a clean soft cotton cloth when necessary, taking care to frequently replace the cloth to avoid scratching the coating finish.
 - For regular general washing mild detergents such as 1/32 diluted TSP (Tri Sodium Phosphate), Dawn, Murphy's Oil Soap, or Vinegar & Water are recommended.
 - For small spot cleaning it is acceptable to use Windex or Isopropyl Alcohol, but avoid scrubbing the same spot repeatedly as this could soften or damage the coating finish.
 - It is recommended to apply any acceptable cleaning solutions to the surface of the siding using a standard plump spray bottle, followed by rinsing the surface of the siding with a garden hose.
 - The finish on Celect is resistant to mildew however, should this occur, standard laundry bleach can be added to the cleaning solution at a ratio of 1 part bleach to 10 parts water (13 ounces per gallon)
 - Avoid using solvents such as nail polish remover, acetone, MEK, Butyl Carbitol, et..., as these chemicals will damage the coating finish.
 - Avoid using bleach or cleaners which contain bleach such as Clorox Cleanup, as these cleaners may permanently discolor the coating finish.
 - Avoid using any cleaners containing abrasives of any sort such as soft scrub, as these abrasives may scratch the coating finish.
 - Avoid using scrub brushes.
 - Avoid pressure washing the siding at high pressure as this may damage the siding and or coating finish.

Replacing a Damaged Panel

Using a circular saw, set the depth of the blade deep enough to cut just through the face of the damaged panel but not through the wall sheathing.

- Cut a 1" strip along the length of the panel just under the panel above (Fig. 1).

IMPORTANT: Stop approximately 1" from both ends at the seams.

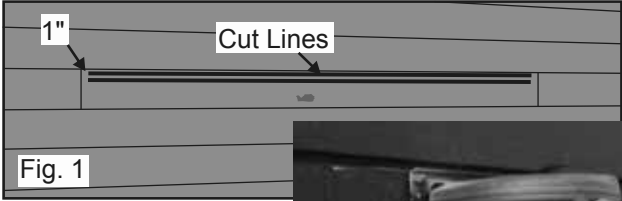

- Finish the cuts at the seams using a utility knife being careful not to cut into or damage the adjacent panel(s). On a right end seam, you will need to use a flat blade screw driver or narrow chisel to finish the cuts behind the seam (Fig. 2).
- Remove both the 1" strip and the remaining bottom section of the panel.
- Next remove the top portion or nailing hem portion of the damaged panel. To achieve this, you will need to cut the fasteners holding the piece. An oscillating tool, reciprocating saw or a hack saw blade can be used.

- Install Celect panel replacement clips by inserting the locking tab end of the clip into the gravity lock on the panel above the one you removed. Nail the clip to the wall. Place clips at a minimum of 16" apart. This will secure the bottom of the panel (Fig. 3).

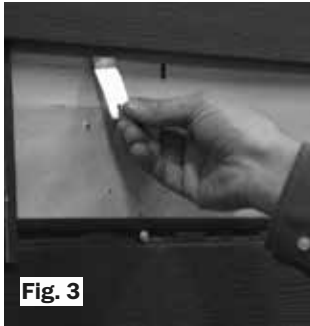

- Locate a new panel that is as close to the length of the damaged panel as possible. You may have to adjust the adjacent panel(s) slightly to achieve a necessary measurement.
- Remove the nailing hem of the replacement panel using a utility knife cutting along the indentation just below the nailing slots.

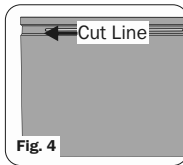

- If the panel will be seamed on the right end, measure up from the bottom of the panel 2" along the seam locking tab. File down the locking tab flush with the rest of the tab with a knife. This will allow for easier installation at this seam.



- Begin the installation of the replacement panel installing the bottom right end of the panel behind the adjacent panel first, then lift the rest of the panel into place making certain that the top edge of the panel is sliding under the panel above it.



- Lastly, using only your hands, “smack” the face of the replacement panel in a downward motion lowering the panel over the nailing hem of the panel below it until the lock is fully engaged.



Typical Window Profile Illustrations

Picture Framing

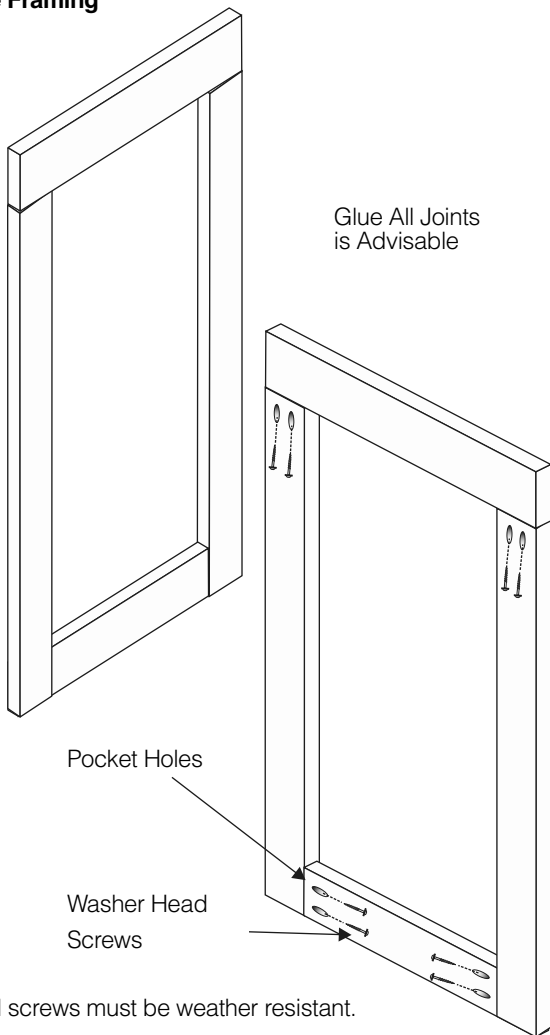

NOTE: All screws must be weather resistant.

Typical Window Profile Illustrations

Adding Rams Crown and Sill Nose

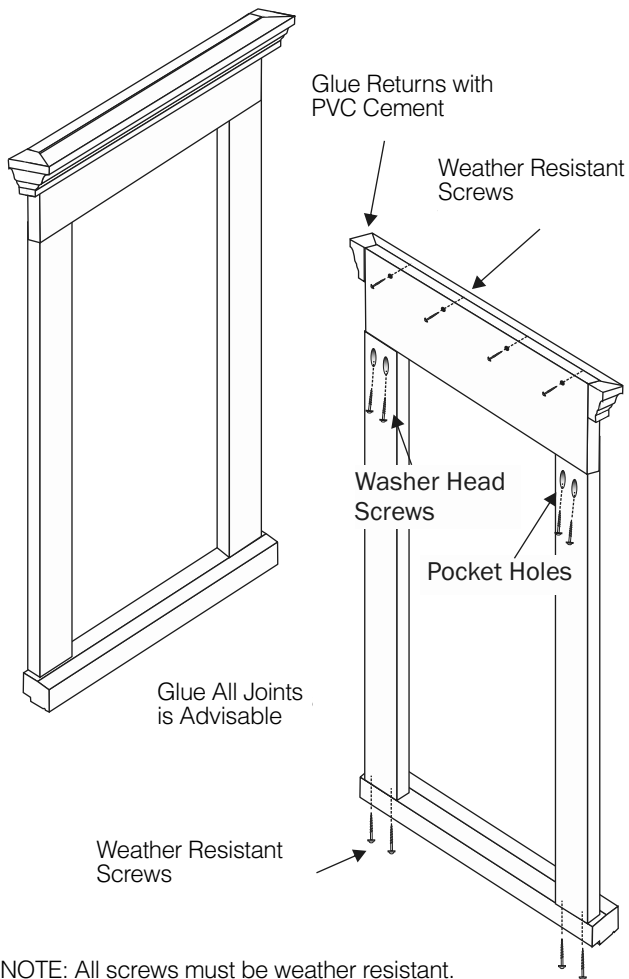

Installing an Apron

- Begin by fastening the apron to the jamb trim. (It is typical to use a wider board for the apron so as to result in a similar apron reveal below the sill nose.)
- Run a bead of PVC cement on apron where sill will be placed.
- Next install the sill nose with screws as shown.

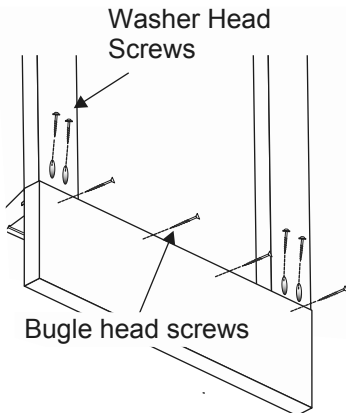

Celect Brickmould

- Miters should be glued and secured with weather resistant screws as shown below.
- Cortex® or Pro Plug® screws and matching plugs should be used when installing Celect trim. Space the fasteners no more than 16" apart and no closer than 2" from the end of the trim. Make sure not to fasten through the siding or into the expansion pocket.

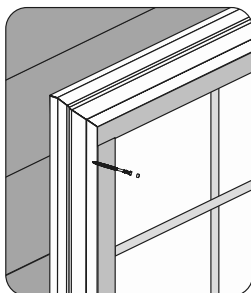
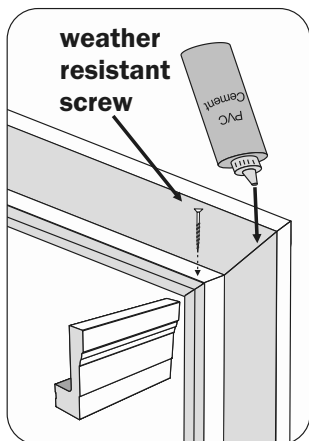

Celect Window & Door Trim

- If corners are to be mitered, they should be glued and secured with weather resistant screws as shown in figure 1.
- Square corners can be achieved if desired by removing material on the back of the piece as shown in figure 2.
- Cortex® or Pro Plug® screws and matching plugs should be used when installing Celect trim. Space the fasteners no more than 16" apart and no closer than 2" from the end of the trim. Make sure not to fasten through the siding or into the expansion pocket.

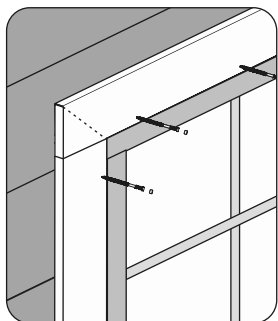
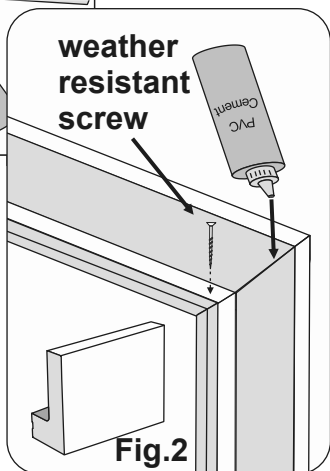
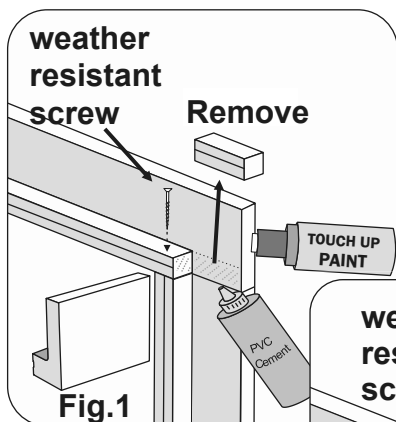

Celect® Canvas Cellular Siding

Important Notes

- Installation Sequence varies depending upon siding profile and particular scenario. Be sure to consider the basic principles of Celect siding installation (i.e. Expansion and contraction, etc.) when deciding how and in what order particular pieces should be painted and installed.
- With the exception of the Celect shake profile, panels must be installed using “pocketed” trim and accessories. See complete Celect Installation Handbook for detailed instructions.
- Because pre-formed inside corner trims are always installed prior to the panels, the last 4" of the panels that are to be inserted into the inside corners must be painted prior to their installation on the wall.
- Paints used on Celect siding and trim must be “vinyl safe” with an LRV rating of 57 and above.

Horizontal Lap and Vertical Board & Batten

With Cellular PVC Trim or Wood

1. Install panels
2. Paint panels
- 3a. Complete install using Celect prefinished trim
OR
- 3b. Install unfinished trim
4. Mask off panels
5. Paint trim

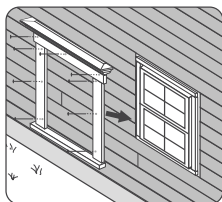

With Spec Series Trim

1. Paint last 4" of panels to be inserted into trim.
2. Install Spec Trim
3. Mask off trim
4. Install panels
5. Paint panels

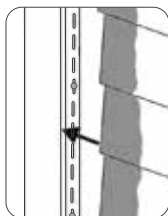

Celect Shake

With Pocketed trim such as cellular PVC

1. Paint right 1" of all panels (Shiplap Joint)
2. Install panels
3. Paint panels
- 4a. Complete install using Celect prefinished trim
OR
- 4b. Install unfinished trim
5. Mask off panels
6. Paint trim

With Spec Series Trim

1. Paint right 1" of all panels and last 4" of panels to be inserted into trim
2. Install Spec Trim
3. Mask off trim
4. Install panels
5. Paint panels

Direct to trim (no pocket)

1. Install trim
2. Paint right 1" of all panels
3. Install panels
4. Paint panels
5. Mask off panels
6. Paint trim

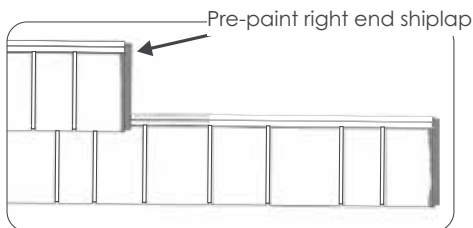

*Canvas (unpainted) is only available in our siding profiles, Inside and Outside Corners, and our blocks and mounts.

Royal® Spec Series™ Trim

Product Offering

Outside Corner Post

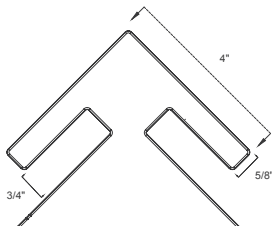

- Product code: SPECOCF
- 10' long with 8 pieces per box

Inside Corner Post

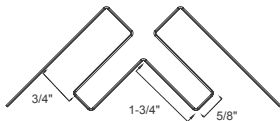

- Product code: SPECICP
- 10' long with 4 pieces per box

Wide Faced J Channel

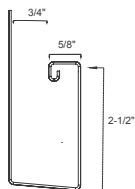

- Product code: SPECWFJ
- 12.5' long with 8 pieces per box

Spec Series Accessories

Unlike traditional Celect accessories, *Celect Spec Series* must be installed prior to the installation of the Celect panels.

Spec Series Outside Corner Post

- Place the corner post in position, allowing a 1/4" (6.4mm) gap between the top of the post and the eave or soffit. Position a nail at the top of the upper slot on both sides of the corner post, leaving a gap of approximately 1/32" (0.8mm) between the nail heads and the corner posts. The corner post hangs from these nails. The balance of the nailing should be in the center of the slot, 8" to 12" (203mm to 305mm) apart, again leaving 1/32" (0.8mm) between the nail head and the corner post. This allows for the expansion and contraction to occur at the bottom. The corner post should extend 1-1/2" (38mm) below the bottom of the starter strip. Make sure the posts are plumb (i.e., vertically straight) and square to the wall. Cut away any exposed nail hems.
- If more than one length of post is required, cut the bottom of the upper post and install as shown.

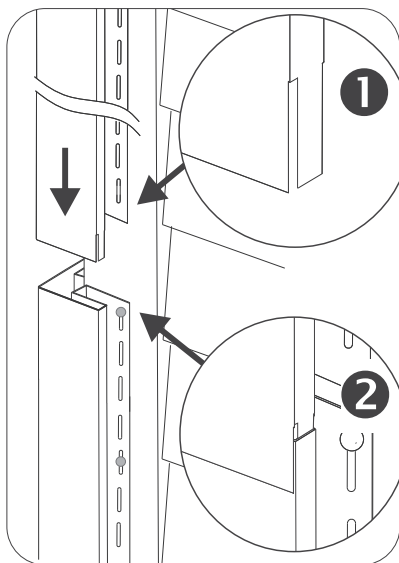

Inside Corners

- Inside corner posts are installed in the same manner as the outside posts.
- If more than one length of post is required, cut and install the second post as shown.

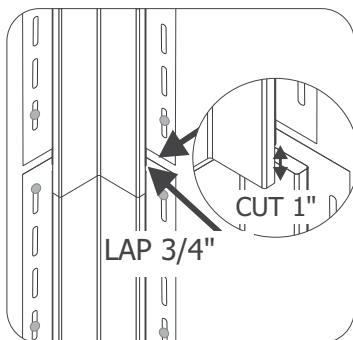

Wide Faced J Channel

- Wide faced J can be used as a siding receiver around areas such as windows, doors and anywhere the panels terminate and the panel expansion gap needs to be concealed.
- Fasten the channel every 8" to 12" (203mm to 305mm) placing the fastener in the center of the nailing slot(s) leaving approx. 1/32" (.8mm) space between the head of the fastener and the vinyl. Leave 1/4" where the channel terminates at corners, etc. to allow for expansion.
- If more than one length of channel is required or installing in a gable, cut and lap the two pieces as shown.

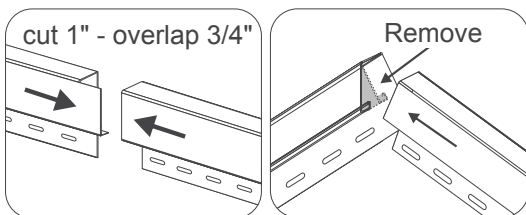

Top Course Securing Options

Option 1

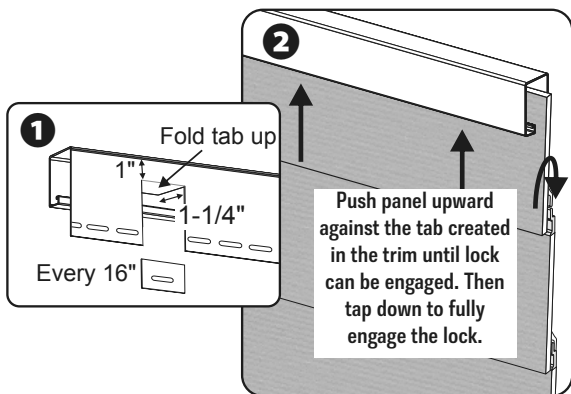

Option 2

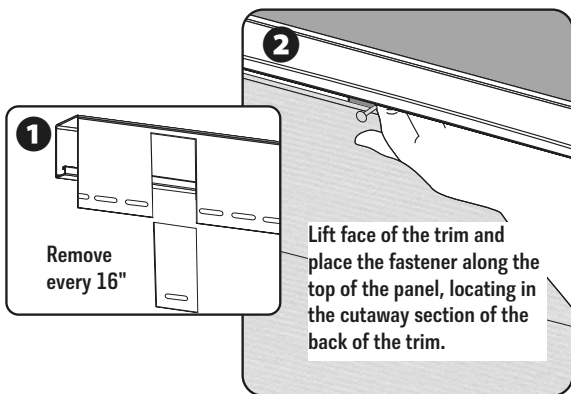

Trimming Around Windows

- When installing wide faced J channel around windows and doors, begin with the sill or bottom piece, then the side jambs and finally the header piece.
- All notches and miter cuts are 2-1/2" (63.5mm).
- Overlap miters over adjoining pieces as shown.
- Make sure to retain tabs as shown.
- Secure the channel every 8" to 12" (203mm to 305mm) loosely, leaving approximately 1/32" (.8mm) gap between the head of the fastener and the vinyl.
- Secure in the center of the nailing slots except for one fastener at the top of the upper most slot on both side jamb pieces to hold in place. These fasteners must be loose also.

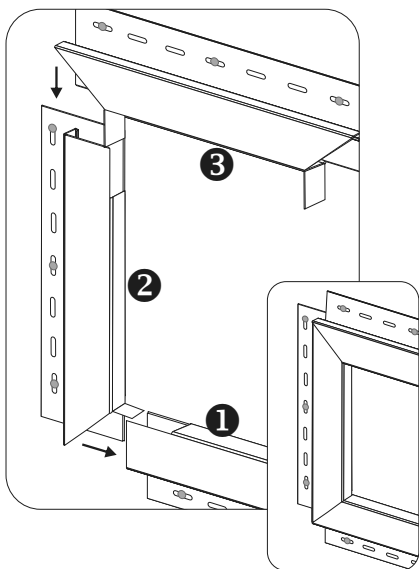

Installing Shutters

Do not fasten shutters through a course of siding unless the siding panel(s) are either;

- one full panel or less in length such as between two shutters (upper diagram)
- or
- free to expand away from the shutter (lower diagram)

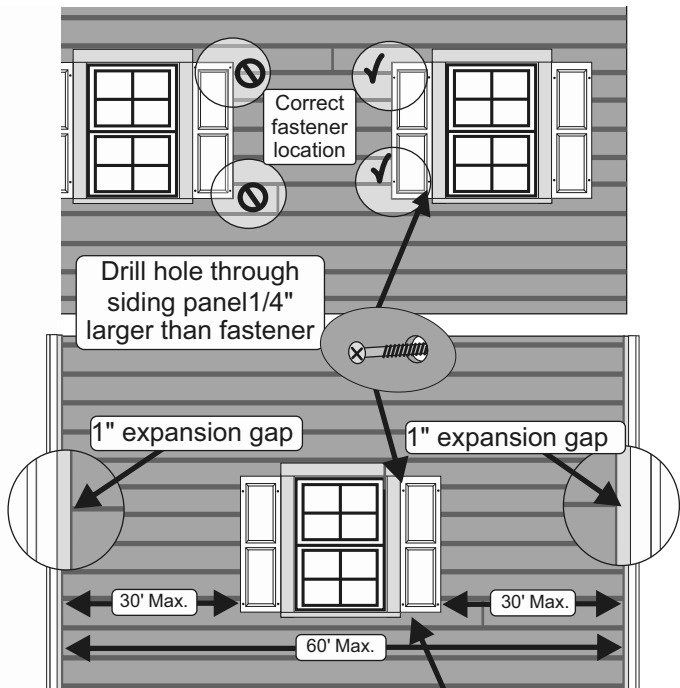

Installing a shutter through a panel effectively "pins" that panel. Therefore, the panel must be able to expand and contract away from that "pin" point. To assure panel movement, center all siding fasteners in the nailing slots in the courses pinned by the shutter fasteners. These courses must have adequate expansion room at the ends (1") and can be a maximum of 30' in length. If the siding course has been center pinned already, the shutter can not be installed.

Frequently Asked Questions

What is the best method for cutting Celect?

Celect siding panels are most easily cut using standard wood cutting tools such as a miter saw or circular saw for straight cuts and jig saw around obstacles. The best tool for Celect Trim is a power miter saw.

Do the cut ends need to be sealed?

No, not necessarily. The only reason to coat them is if the ends are going to be visible. This way the finish color will match the adjacent sides of the part.

Where and when can I use caulking?

The use of caulking should be held at a minimum. If it is desired for esthetic reasons, caulking can be used around window and door trim, etc. Never caulk at any expansion gaps such as in trim pockets or at the top of corners.

My existing windows have a built in J channel. Do I still need additional trim around the window?

Typically yes. Celect horizontal profiles require 1/2" to 1" expansion gaps along the jams of windows and most built in channels are only 3/4" deep. This means that the end of the panel could contract to the point that it would be visible outside the pocket of the channel. The same holds true for Celect Board & Batten panels only not at the jambs but above and below windows for the same reason. Unless the built in trim is at least 1" in depth, additional trim should be installed.

Can Celect siding and trim be repainted?

Yes. We recommend 100% acrylic latex paint. If you're going to paint the product a darker color, consult the paint manufacturer for the LRV (Light Reflectance Value). Painting Celect products with paint 56% or darker on the LRV scale voids the product warranty. There are paint manufacturers that sell coatings specifically designed for PVC. These paints are typically referred to as "vinyl-safe" paints or "heat reflective" coatings.

Contractor Check Lists

Wall Preparation Check List

- Solid, flat, nailable surface (OBS, Plywood, fanfold over solid existing siding)
- Weather protective barrier (wrap, etc.)
- Code compliant flashings

Suggested Tool & Supplies Check List

- Miter saw (60-80 tooth blade) with stand or table to support material
- Saw gorses or layout table for trim assembly
- Cordless drill/driver
- Basic hand tools (hammer, utility knife, tape measure, level, chalk line, square, etc.)
- Kreg Jig® (trim assembly)
- Circular saw
- Optional: jig saw, router, etc.
- Cortex® or Pro Plug® trim screws and Celect plugs
- Kreg Blue Coat® 1-1/4 course thread ext. screws
- Kynar® touch-up bottles
- Professional grade PVC Cement
- Super glue and activator if available
- Celect fixture mount blocks (as needed)
- Weather resistant 1-1/2"-2" nails (roofing)

Notes

SIDING & ACCESSORIES TRIM & MOULDINGS ROOFING
STONE WINDOWS OUTDOOR LIVING

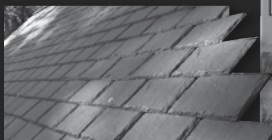

BE BOUNDLESS™

**THE PRODUCTS TO DO EVERYTHING.
THE POWER TO DO EVEN MORE.**

There are no limits to how far we innovate,
how deeply we express, how strongly we
commit and how boldly we go.

Together let's Be Boundless™.



Westlake
Royal Building Products™

© 2024 Westlake Royal Building Products

Celect® Cellular Composite Siding
CelectPVC.com | 855-769-2585
Item # 96103C | CEL160402 3/24